

## DC PM Motor 75V 1500RPM 150W / 300W

65189-572

### DESIGN FEATURES

- Replaceable brushes
- Reversible rotation
- Zinc plated corrosion protected housing
- Aluminium/Zinc endshields with ball bearings
- Class F insulation (Max ambient 40°C)
- UL recognised component (E303615)
- Enclosure: IP 54\*
- Cooling: IC 410 (TENV)
- Designed to BS 5000-11  
BS EN 60034  
IEC 60072

\* IP rating only applies once B14 is mounted to component

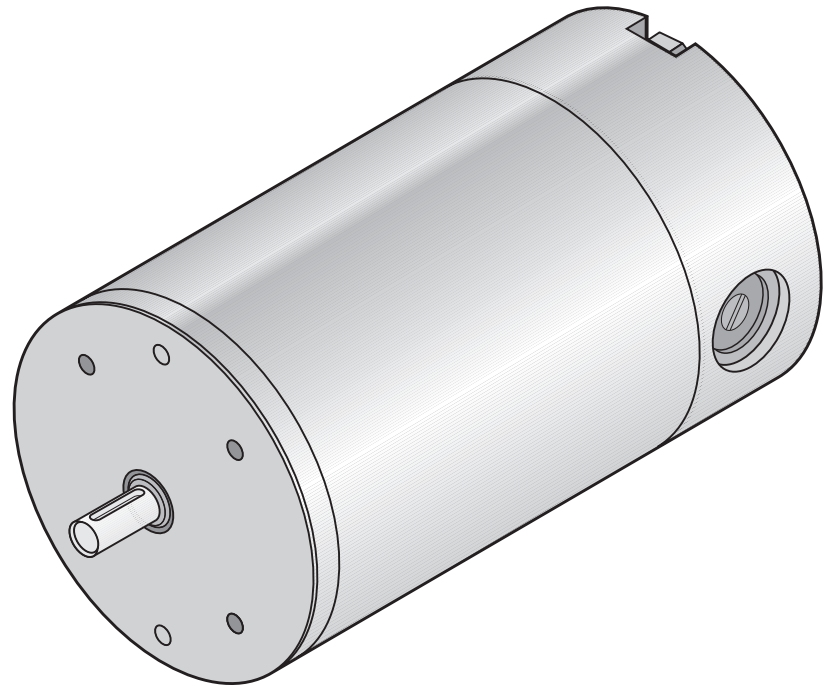

### PERFORMANCE DATA

#### Continuous Rating (S1 Duty Cycle)

Torque (Nm)	1.00
Speed (RPM)	1500
Power (W)	150
Current (A)	3.0

#### Short-time Rating (S2 Duty Cycle 10min)

Torque (Nm)	2.50
Speed (RPM)	1150
Power (W)	300
Current (A)	6.9

#### No Load

Speed (RPM)	1700 (+/- 5%)
-------------	---------------

#### Stall

Torque (Nm)	7.54
Current (A)	19.7

Max Efficiency	68%
Weight	4.3Kg

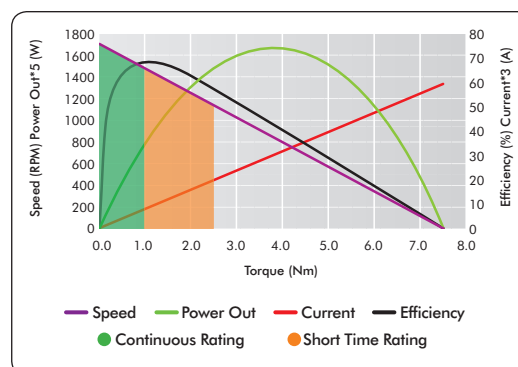
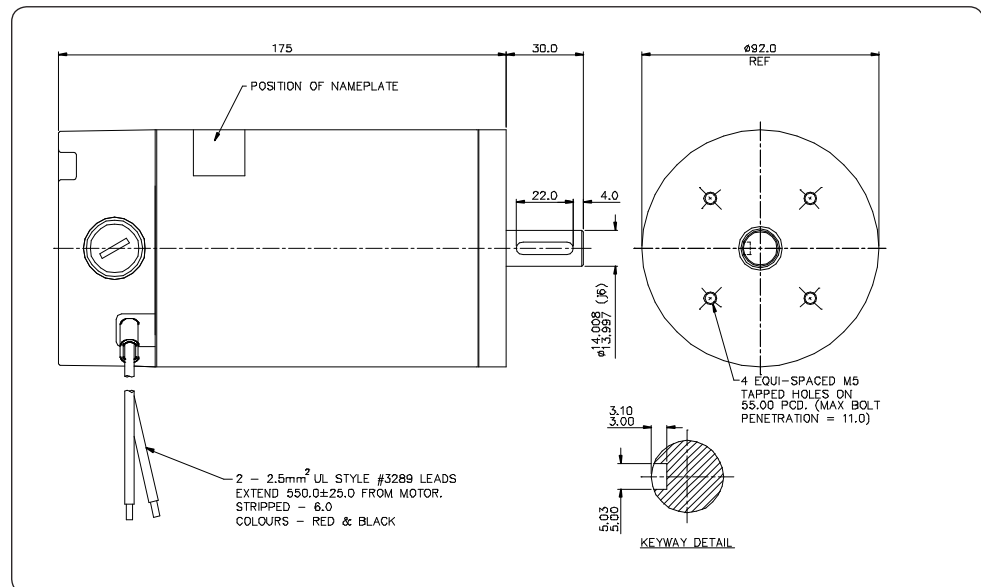

### AVAILABLE OPTIONS

- Mounting and connection (Range of standard IEC flanges and bases available)
- Terminal box
- Electromechanical brake (1.5Nm)
- Rear output shaft
- Painted finish
- RFI suppression

www.lemac.com

LOTHIAN ELECTRIC MACHINES LIMITED  
HOSPITAL ROAD · HADDINGTON · EAST LOTHIAN · EH41 3PD  
TEL: 01620 828700 FAX: 01620 828730  
info@lemac.com